

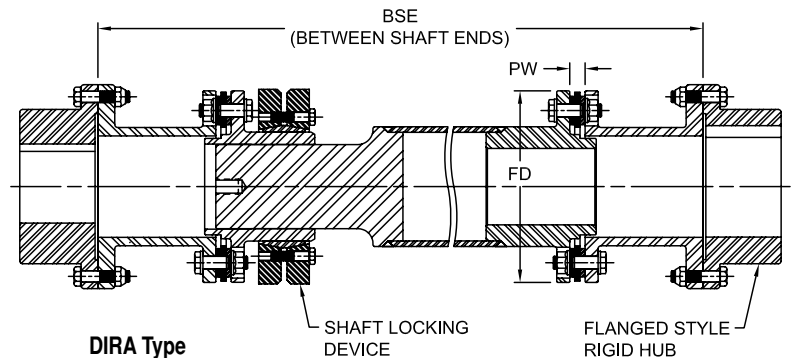

**DIRA-6 and DILRA-6 Type**

**Drop-In Center**

The DIRA and DILRA Type couplings are designed to be direct replacements for floating shafts in flanged series floating shaft gear couplings. This type uses existing or Lovejoy supplied rigid F-Style gear coupling hubs. The DIRA/DILRA are similar to the DIR and DILR Types with the exception these incorporate the use of an SLD shaft locking device to make length adjustments instead of shims. The standard axial adjustment is +/- 2.0 inches for this type of coupling. Custom length adjustment amounts can be provided on request. The DIRA is provided with rigid hubs. The DILRA can be manufactured to serve as a direct drop in replacement for use with existing rigid hubs without disturbing or moving the equipment. All spacers are manufactured to the customer's specified length and are sized using a service factor of 2.0. The coupling has two flex planes (one at each disc pack) so it can accommodate parallel misalignment by the angular misalignment in each disc pack and it is suitable for axial displacement within specified limits.

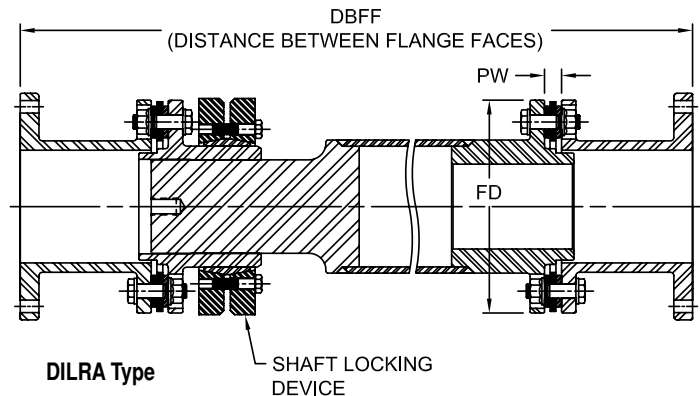

**DIR / DILR - 6 Performance and Dimensional Data**

Size	Nominal Torque		Peak Torque		Max Speed RPM	FD		PW		Axial Misalignment $\pm \Delta Ka$		Angular Misalignment Degrees
	in-lb	Nm	in-lb	Nm		in	mm	in	mm	in	mm	
132-6	9,700	1 100	19,500	2 200	Maximum Speed is determined by the length and critical speed of the spacer assembly	5.20	132	0.331	8.4	0.102	2.6	1.5°
158-6	17,700	2 000	35,400	4 000		6.22	158	0.441	11.2	0.122	3.1	
185-6	29,200	3 300	58,400	6 600		7.28	185	0.551	14.0	0.146	3.7	
202-6	40,700	4 600	81,400	9 200		7.95	202	0.610	15.5	0.150	3.8	1°
228-6	62,000	7 000	123,900	14 000		8.98	228	0.689	17.5	0.165	4.2	
255-6	90,300	10 200	180,600	20 400		10.04	255	0.807	20.5	0.185	4.7	
278-6	125,700	14 200	251,400	28 400		10.94	278	0.835	21.2	0.205	5.2	
302-6	177,000	20 000	354,000	40 000		11.89	302	0.961	24.4	0.224	5.7	
325-6	221,300	25 000	442,600	50 000		12.80	325	1.024	26.0	0.256	6.5	
345-6	274,400	31 000	549,000	62 000		13.58	345	1.110	28.2	0.272	6.9	
380-6	374,400	42 300	749,000	84 600		14.96	380	1.260	32.0	0.299	7.6	
410-6	505,000	57 100	1,011,000	114 200		16.14	410	1.307	33.2	0.323	8.2	
440-6	651,000	73 500	1,301,000	147 000		17.32	440	1.433	36.4	0.346	8.8	

Note: ■ Axial misalignment is given for two disc packs, angular misalignment is given for one disc pack.